



# TRACER

- | Indoor Shuttle | High-speed AGV
- | Explore the fun of indoor mobility

## » Indoor Two-Wheel Differential Wire-controlled Chassis

TRACER, as a two-wheel differential AGV, has unique advantages in the field of indoor transportation. Its small and flexible structure enables it to freely shuttle in various indoor environments. Its single handling efficiency has great advantages due to the high bearing capacity in combination of the strong power. Provided with the sensing system, it even operates more autonomously. As TRACER features low cost, high efficiency and fast deployment, it is the king of cost performance in indoor transportation scenarios.



## » Flat Design for Free Shuttle

The flat design of the body brings extreme bearing capacity. The two-wheel drive puts the universal wheels in motion, which can realize differential rotation and free shuttle in the indoor environment. It is additionally equipped with swing arm independent suspension which leads to easy surmounting of small obstacles.

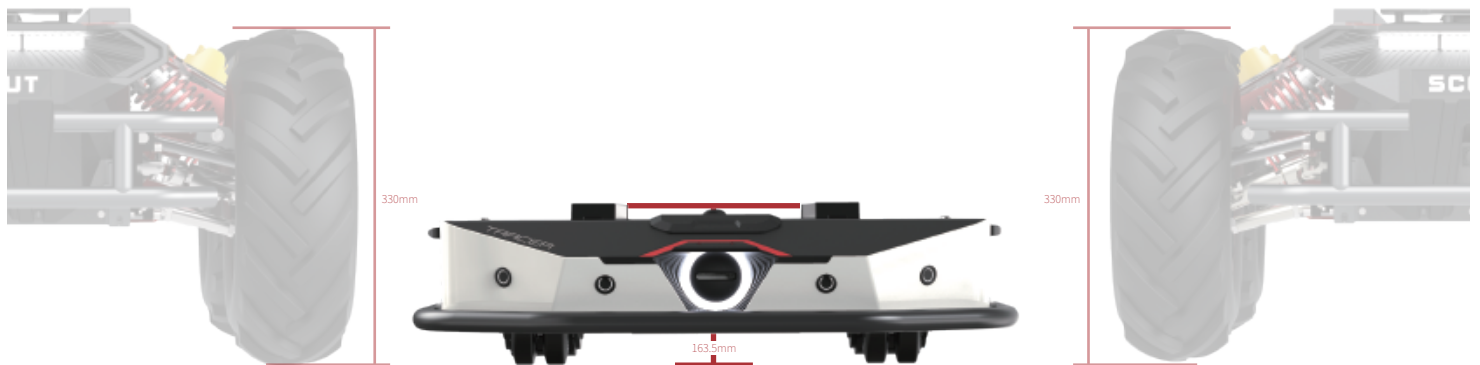

## » Multiple-load Expansion, Rapid Secondary Development

TRACER can be adapted to lightweight operation mode. Users can communicate with the main control through CAN bus protocol, and the open source SDK and ROS\_ PACKAGE are also provided.



Installation positions are reserved for slide rails and front & rear sensors, for quick adaptation of lightweight automatic driving system.



Supports customized design of sensor AI profile bracket



Supports access of more advanced automatic driving system (such as ROS, Apollo, etc.)



## >> SPECIFICATIONS

Dimensions	685*570*155mm	Drive Form	Two-wheel Differential Steering Drive
Track	360mm	Operating Temperature	-20~60°C
Weight	28-30KG	Operating Time	4h
Minimum Ground Clearance	30mm	Charging Time	2h
Rated Progressive Load	100KG	Outward Supply	24V5A
Climbing Capacity	≤8°	Battery	24V/15Ah(Standard) 24V30Ah (Optional)
Minimum Turning Radius	0m (Can Rotate In Place)	Code Wheel	1024 Lines Photoelectric Incremental Code Wheel
Obstacle Ability	10mm	Motor	2 X 150W Brushless Servo Motor
Suspension Form	Independent Suspension With Rocker Arm	Communication Interface	Standard CAN RS232
MAX Speed	6KM/H	Materia	Steel Body

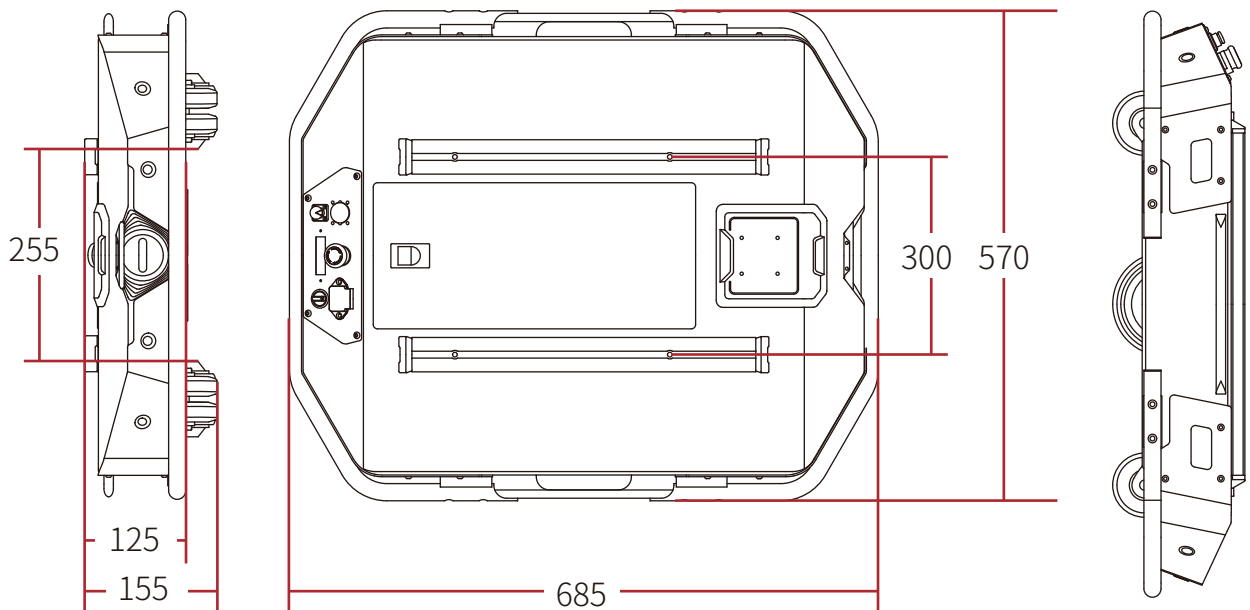

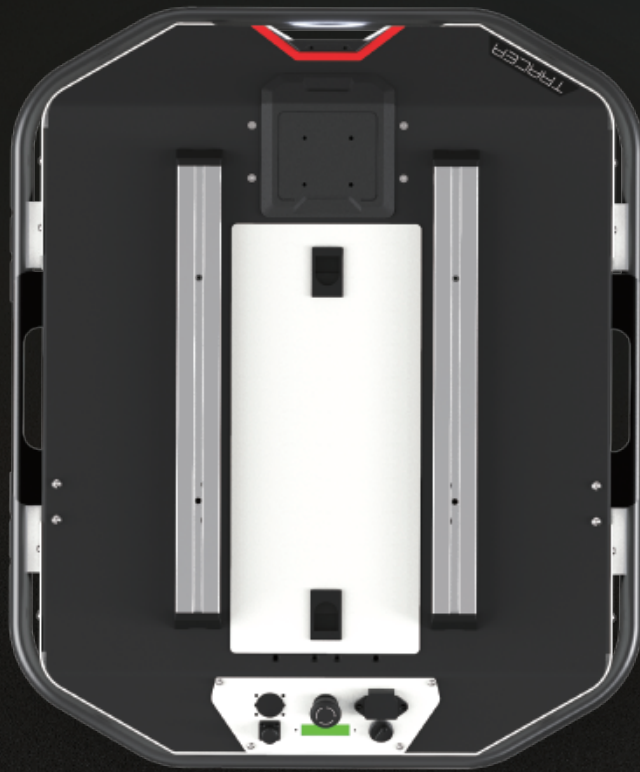

LinkedIn



Youtube

[WWW.AGILEX.AI](http://WWW.AGILEX.AI)

AgileX Robotics CO., Ltd

Email: [sales@agilex.ai](mailto:sales@agilex.ai)

Tel: +86-769-22892150

+86-19925374409